

The image shows a close-up of a CNC machine's spindle and tool bit cutting into a metal workpiece. A semi-transparent 3D CAD model of the part is overlaid on the workpiece, with cyan lines indicating the tool's path. The Siemens logo is in the top left corner.

SIEMENS

Siemens PLM Software

CAM Express

Delivering machine tool value

[siemens.com/plm/camexpress](https://www.siemens.com/plm/camexpress)

Delivering machine tool value

Capable, proven CAM software, providing excellent programming range and depth, delivering maximum machine tool performance, CAM Express software is easy to deploy, easy to learn and cost effective to own.

Efficiency in a competitive global market

To be competitive in a global market manufacturers and machine shops need to take full advantage of the most efficient, innovative and capable machine tools such as high-speed mills, 5-axis machines or mill-turn multifunction equipment.

To deliver the expected return on these investments it becomes imperative to be able to utilize these advanced machine tools effectively and to do so as quickly as possible.

At a small percentage of the cost of the machines, advanced CAM software, supported by a top class supplier, can leverage a significant incremental value from the purchase of these new machine tools.

High performance with a low cost of ownership

To meet budgets and business targets customers need CAM software applications that combine range and depth of capability plus advanced technical performance with a low total cost of ownership.

Incremental return on the investment in new machine tools is a key factor reducing the true cost of ownership, and the value of advanced CAM software.

Competitive software pricing, ease of deployment and ease of use with a short learning curve are direct factors to a low cost of ownership.

A system that offers the user help on how to tackle an NC programming task and then automates some standard parts of that job, can go a long way towards making the less experienced NC programmer more productive sooner – reducing costs.

Maximizing the value of advanced machine tools

CAM Express is an in-depth, highly flexible system that allows users to maximize the value of their investments in the latest, most efficient and most capable machine tools

Proven value

Top rating for Siemens PLM Software

CIMdata considers the CAM offering from Siemens PLM Software to be “among the strongest product offerings in the industry.”

From CIMdata’s 17th annual NC Market Report

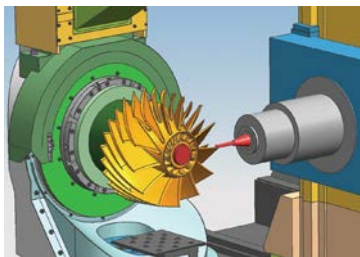
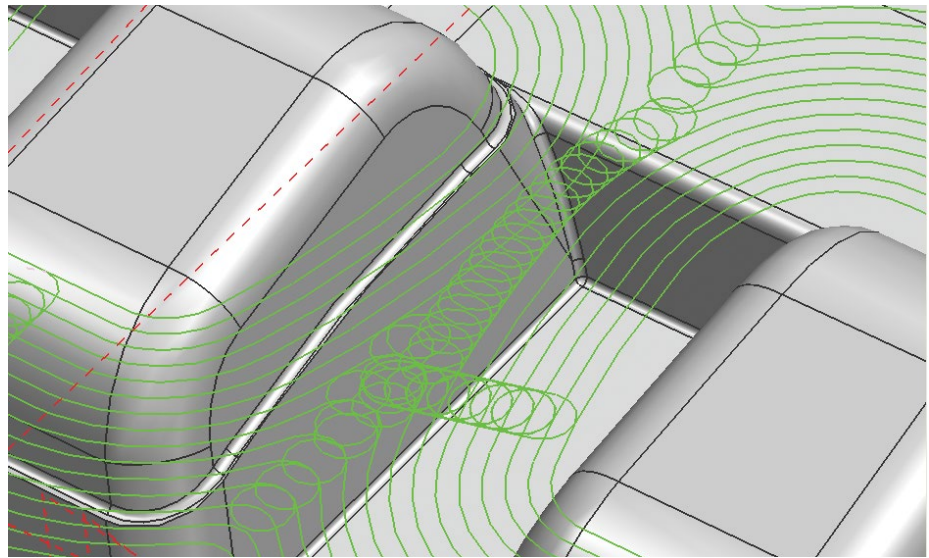

In depth, proven NC programming from Siemens

Siemens PLM Software has over 25 years experience and a wide range of NC programming customers from the largest global engineering companies to many thousands of small machine shops.

Taking advantage of its acknowledged capability in CAM software, Siemens offers CAM Express Total Machining software – a Solid Edge® manufacturing solution – to provide the advanced capability needed by NC programmers to fully utilize advanced, efficient machine tools.

For high-speed milling machines the in-depth functionality, and the customer proven methods that are provided within CAM Express will help maximize the rate of material removal while optimizing tool life – key objectives on high-speed machines.

Being able to accurately machine more complex parts can provide a competitive edge. CAM Express can help maximize the value of new 5-Axis machines by delivering effective NC programs even for the most demanding jobs.

Mill-turn machines can deliver significant shop floor savings. CAM Express has the range and depth of capability needed to address the programming of these machines with their typically innovative configurations.

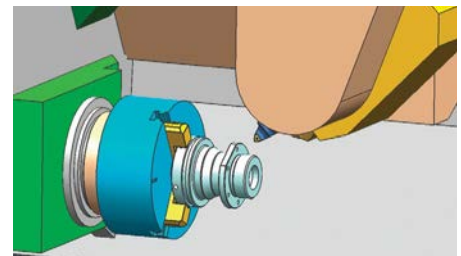
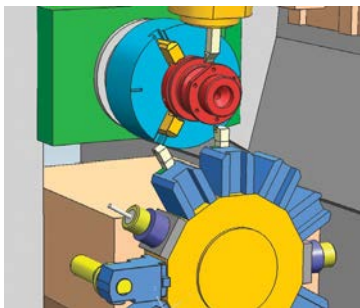

The CAM Express advantage

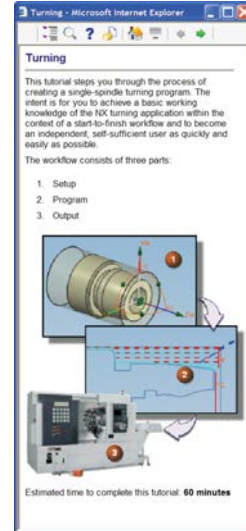
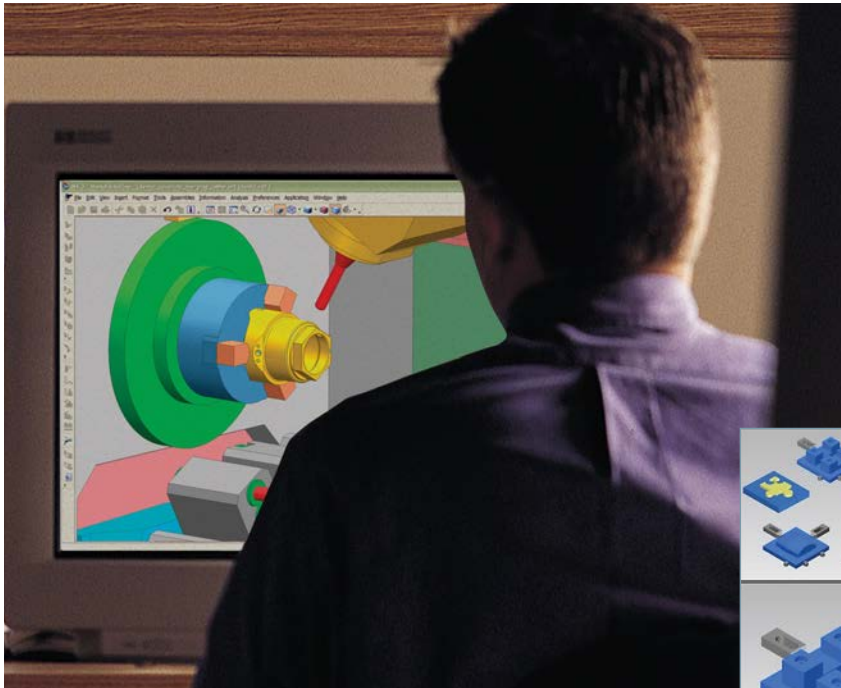

Workflow tutorials assist in rapid startup reducing the time taken to get fully productive.

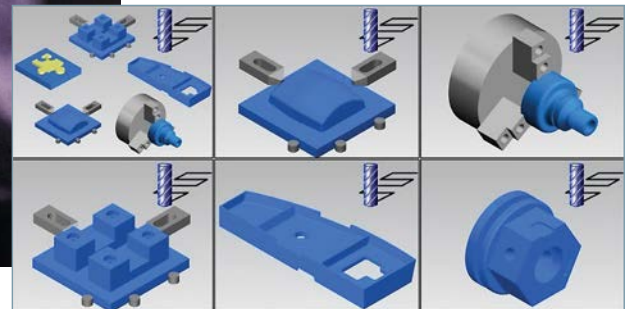

Modular industry focused packages

CAM Express is available in application focused packages to address:

- 2 1/2-Axis Machining
- 3-Axis Machining
- Mill-turn Machining
- Advanced Machining

CAD neutral

CAM Express is designed to be used independently of any specific CAD system. It has key industry translators for data import.

Integrated with Solid Edge and NX

CAM Express is also available for integrated use with Siemens NX™ CAD as well as Solid Edge CAD software based on the same packages outlined above.

A total solution

A complete foundation within each package

Each CAM Express package comes with a comprehensive base of core technology including access to the Siemens online postprocessor library, a graphical postprocessor build and edit application, toolpath verification, CAD file translators, online help, shop documentation output, assembly handling, access to machining parameter library with proven machining data and more.

World-class customer support

Built on Siemens' 25 years of success in the CAM market delivering proven, reliable software, CAM Express is backed up with world-class technical support.

Preconfigured with industry best practices

Preconfigured user environments set the system for immediate use to address typical types of programming and help them apply industry best practices.

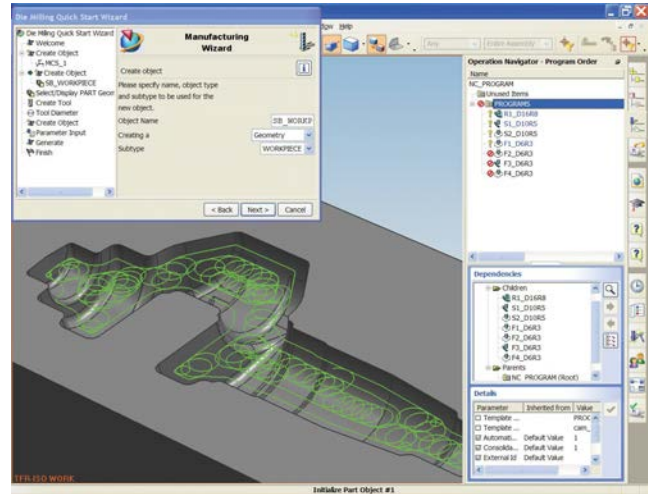
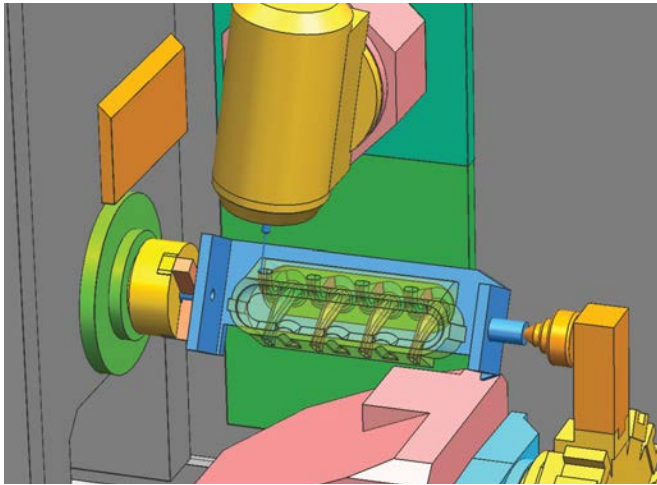

Easy-to-deploy Online post library

Siemens offers online access to a postprocessor library supported by the Siemens Global Technical Access Center (GTAC). Customers can search for and download post files directly into CAM Express saving time, and making it easier to become productive.

Machine tool support kits

Advanced machines need advanced posts and complete 3D simulations. Siemens works with machine tool makers to create and offer proven combinations of these with examples, ready-to-go setups and documentation.

Proven value

“CAM Express is targeted to provide in depth capability for clearly defined key areas of machining, such as mold and die or mill-turn machining, in software that is easy to deploy and to use. Ready access to key elements such as a library of postprocessors as well as preconfigured software with industry best practices will make it easier and faster for customers to become productive and to do so with lower costs.”

Alan Christman
Chairman, CIMdata

Easy-to-use Navigators

CAM Express has a set of consistent navigators that manage key elements of the system. These make the software powerful yet easy-to-use.

Using templates

Templates are used extensively throughout the system to capture and re-apply methods, geometry, setups, operations and tool selections. They are easy to use and streamline programming tasks.

Wizards

Wizards take the user to a whole new level of automated interaction. Almost anyone can follow the steps. CAM Express comes with the drag-and-drop wizard builder.

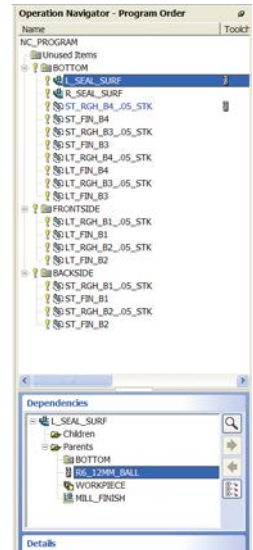

A full range of capability

CAM Express offers a wide range of in-depth NC programming capabilities – avoiding the need for and the cost of multiple CAM systems in the machine shop, providing user flexibility and maximizing the value of the software investment in one product.

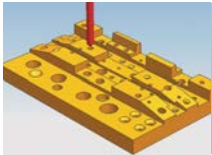

Drilling – addresses drilling, reaming, boring, tapping, peck drilling, and custom cycles. Automated hole making is available with the feature based machining options.

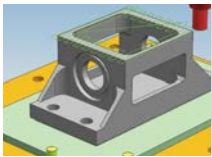

2 1/2- Axis milling – 2 1/2-Axis roughing patterns can be applied based on basic boundary data or solid geometry. Zig-zag, offset, and plunge milling are examples of the toolpaths provided. High-speed roughing toolpaths such as trochoidal are available here. Feature based machining functions automate the identification and programming of slots and faces.

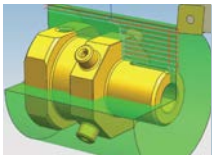

Turning – a complete solution that is easy enough to use on simple programs and capable enough to tackle your toughest geometry in multi-spindle, multi-turret applications. The system can work with solids or wireframe or even 2D profiles.

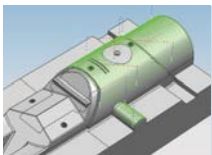

3-Axis milling – for roughing, rest milling, semi-finishing, and finishing of contoured surfaces, with a complete set of milling strategies to address the challenges of complex geometry. This capability includes additional functions needed for high-speed machining.

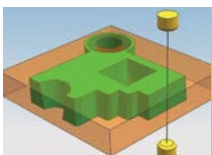

Wire EDM – a complete solution for programming 2 4-Axis wire EDM machines. A range of wire operations is available, including multi-pass profiling, wire reversing and area removal.



Synchronization – a graphical means of displaying an unlimited number of channels, with scrolling code in a choice of formats, time displays and with functions to add wait and sync codes. The Synchronization Manager is directly linked to the internal postprocessor and runs from posted output for the greatest accuracy.

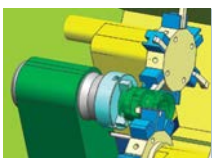

Machining simulation – to avoid tying up a machine in unproductive prove-outs, the integrated machine tool simulation provides a more complete simulation than most systems with its machine code driven motion.

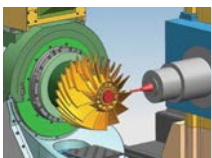

5-Axis milling – CAM Express offers highly flexible 5-Axis programming functions combining highly automated elements for tedious tasks such as geometry selection and detailed user control for precise machining.

Comprehensive foundation

CAM Express includes capabilities that other systems can't provide or charge a premium for. NC programmers need a full complement of capabilities that support and enhance the programming task.

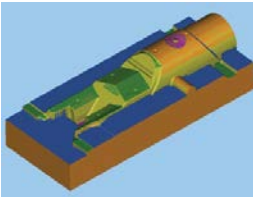

Toolpath verification

With dynamic pan and zoom during playback and visual display of material removal.

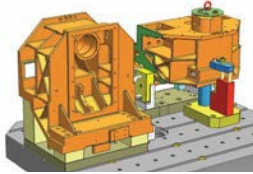

Assembly environment

Use the assembly modeling tools in CAM Express to assemble a detailed machine environment or to position parts and fixtures.

Shop documentation

CAM Express automatically generates shop documentation, including setup sheets, operations sequence information and tool lists. These are output in ASCII text or HTML format for shop floor intranet access.

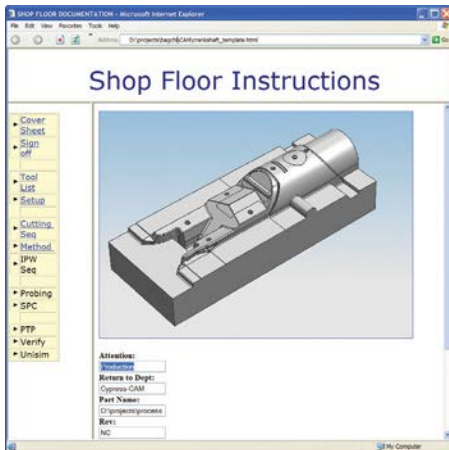

Libraries

Tools, machines, cutting parameters, templates, and posts are all organized for effective re-use and easy selection. Machining parameter data is automatically drawn from the library as operations are created.

Each CAM Express package also includes:

- A full range of CAD file translators
- Model editing capabilities to handle any model manipulation required for NC programming – including the groundbreaking synchronous modeling functions
- A cutting parameters database prepopulated with data for commonly used materials
- Full online help
- Access to the online postprocessor library direct from CAM Express

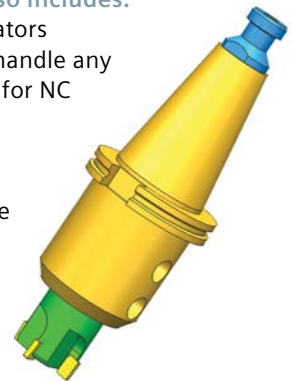

Integrated postprocessing

CAM Express includes a graphical post builder capability. Simple menu selections are all that is needed to build or edit a postprocessor.

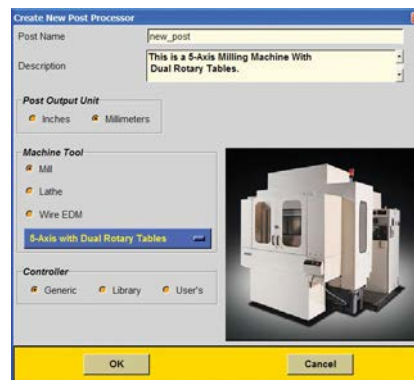

Maximum shop floor efficiency

High-speed machining

High-speed machines have transformed the mold and die business. Finer finishes, better accuracy, fewer electrodes and less bench time are the rewards for manufacturers who can program these machines effectively.

To maximize the value of the advanced toolpath technology CAM Express customers get access to the proven methods and knowledge needed to deliver an effective high-speed machining solution.

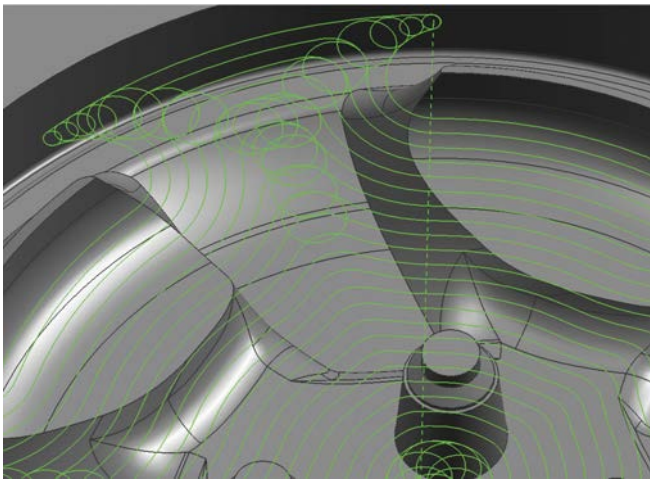

High-speed roughing patterns maintain specified chip loads without overloading.

Libref	Diameter	Length	Cut Depth	Stepover	Surface Speed	Feed per T...	Approach...	Engage...	First Cu
THSO_00451	0.039400	1.181100	0.001600	0.001600	393.700800	0.000800	0	80	60
THSO_00452	0.078700	0.236200	0.003100	0.003100	426.509200	0.001600	0	80	60
THSO_00453	0.118100	0.354300	0.005500	0.005500	492.126000	0.002800	0	80	60
THSO_00454	0.157500	0.472400	0.007500	0.007500	590.551200	0.004700	0	80	60
THSO_00455	0.196900	0.590600	0.011000	0.011000	656.168000	0.005100	0	80	60
THSO_00456	0.236200	0.708700	0.013400	0.013400	787.401600	0.005900	0	80	60
THSO_00457	0.315000	0.944900	0.018900	0.018900	787.401600	0.005900	0	80	60
THSO_00458	0.393700	1.181100	0.025200	0.025200	787.401600	0.006300	0	80	60
THSO_00459	0.472400	1.417300	0.030300	0.030300	918.635200	0.006300	0	80	60
THSO_00460	0.039400	0.196900	0.001200	0.001200	295.275600	0.000700	0	80	60
THSO_00461	0.078700	0.393700	0.002400	0.002400	344.488200	0.001200	0	80	60
THSO_00462	0.118100	0.590600	0.004700	0.004700	410.105000	0.002400	0	80	60
THSO_00463	0.157500	0.787400	0.006300	0.006300	492.126000	0.003900	0	80	60
THSO_00464	0.196900	0.984300	0.009400	0.009400	524.934400	0.004700	0	80	60
THSO_00465	0.236200	1.181100	0.011000	0.011000	590.551200	0.005900	0	80	60
THSO_00466	0.315000	1.574800	0.016100	0.016100	656.168000	0.005900	0	80	60
THSO_00467	0.393700	1.968500	0.022000	0.022000	721.784800	0.006300	0	80	60
THSO_00468	0.472400	2.362200	0.024400	0.024400	787.401600	0.007100	0	80	60
THSO_00469	0.039400	0.275600	0.000800	0.000800	196.850400	0.000500	0	100	60
THSO_00470	0.078700	0.551200	0.001600	0.001600	262.467200	0.001200	0	100	60
THSO_00471	0.118100	0.826800	0.003100	0.003100	328.084000	0.001600	0	100	60

Machining parameter data is automatically drawn from the library as operations are created.

CAM Express addresses the demands of high-speed machining

Uniform material removal

A range of methods, including the latest trochoidal motions, ensures a constant rate of material removal.

Rest milling

Z-level rest milling and valley cutting reserve your smallest tools for only the required regions.

Consistent finish

A range of methods delivers evenly spaced stepovers, regardless of steep or shallow surfaces

Smooth continuous cutting

Free Flow Machining technology provides smooth, uninterrupted cutting patterns that are ideal for high speed machining.

Proven, integrated machining data

Accurate, proven machining data in CAM Express assists the programmer in achieving optimum results.

Fine-tuned output for high-speed machining

Toolpaths are fine-tuned for high-speed machine controllers with uniformly distributed points, smooth interpolations and spline output options.

Managing chatter

Siemens offers machinists a method to calibrate their equipment, avoiding the chatter that limits feed rate and cut depth.

Streamline Operation

Siemens introduces the Streamline Operation to provide a completely new approach to the creation of toolpaths.

The Streamline Operation can be compared to the concept of a fluid flowing through or over the part to be machined.

The result is free flowing paths that naturally follow the contours of the overall part.

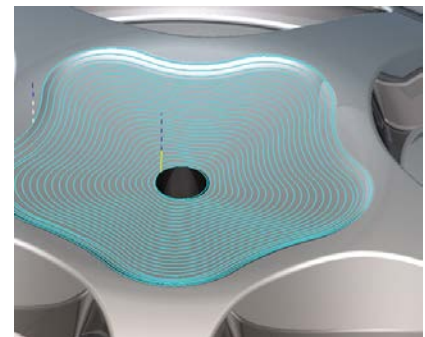

The Streamline Operation provides superior finish quality.

Programming multi-function machines

Multi-turret, multi-spindle, mill-turn machinery is delivering ever higher production efficiency, as one machine replaces several. Your challenge is to program these machines, taking advantage of their innovative features and minimizing cycle times.

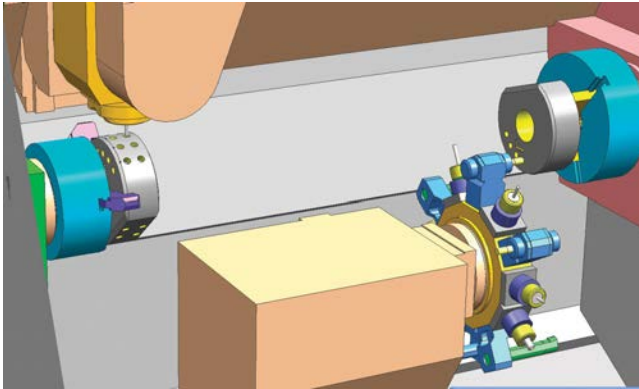

Turning > Milling > Turning

Machine simulation

CAM Express provides accurate machine simulation by using the actual G-codes for simulation rather than the internal toolpath representation. The simulation operates directly with the Synchronization Manager, all inside CAM Express.

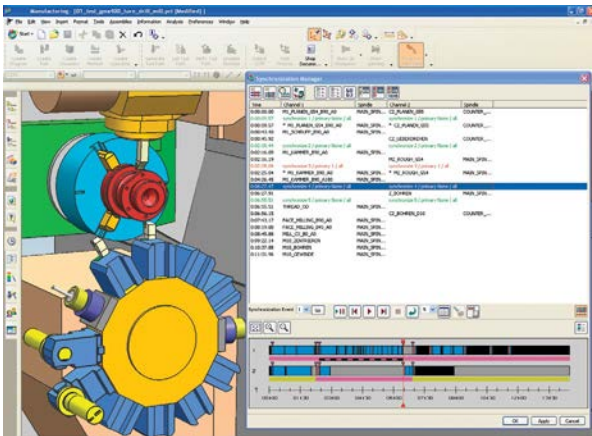

Mill-turning

CAM Express has all the components needed to effectively program multi-function equipment like mill-turn combination machines.

All the elements operate together in one consistent user environment, with the resultant mill-turn program readily displayed in the Operation Navigator.

Postprocessing for multi-function machines

CAM Express has a comprehensive postprocessing capability that allows multi-channel posts to be handled easily. The post-processor connects directly to the toolpaths and machining database rather than interpreting a CL file.

In-process workpiece

Keeping track of the in-process state of the workpiece is a critical component of effective mill-turning. CAM Express utilizes a spun solid technology to provide seamless transfer of workpiece configuration between milling and turning.

Synchronization

Multi-turret and multi-spindle turning centers can be easily synchronized in CAM Express, with full visualization and timing comparisons. These tools provide the essential sequence visualizations that lead to cycle time optimization.

Feature-based machining

Feature recognition

Robust feature recognition capability finds features in the topology of any model, including imported data.

Knowledge base

Powerful knowledge editor applies template processes building blocks to machine a wide range of features.

Programming complex parts

5-Axis Machining

Complex geometry demands the versatility of 5-Axis machine tools. Programming these requires software flexibility with significant user control. Collision checking and accurate machine simulation reduce the need for dry run checking.

Streamlined, automated programming

CAM Express enables fast, accurate machining of typical complex aerospace parts. Geometry selection is highly automated for easier, faster programming and collision checking reduces the risk of errors.

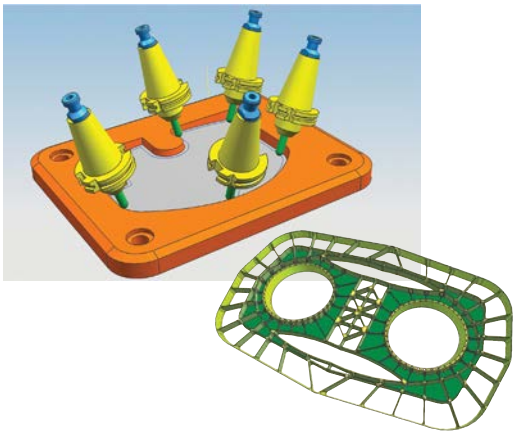

Total user control

When precise control over the tool axis is required as the tool is moved along drive surfaces, CAM Express gives the user a complete drive/part/check capability.

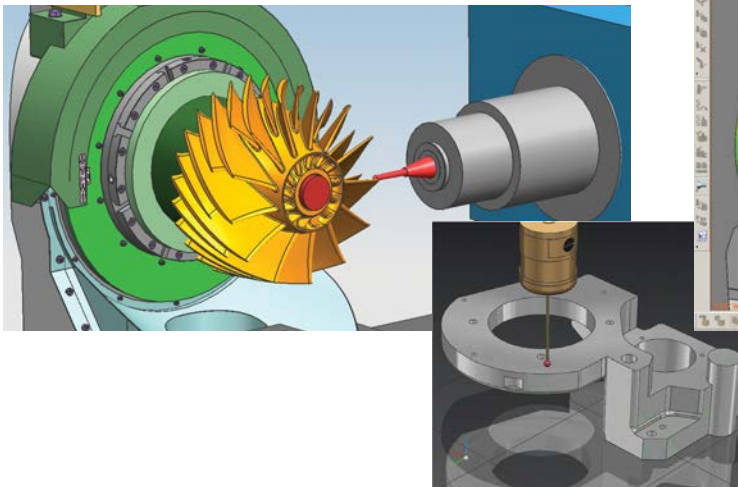

Machining simulation

The integrated machining simulation in CAM Express eliminates the need for separate external software for this task.

Machine code driven simulation

CAM Express simulation is driven by the output from the postprocessor, ensuring that all the motion of the final program is available for review.

Simultaneous display

The user can review simultaneous metal removal with a live toolpath in the context of a full machine tool simulation, with dynamic pan and zoom of the view.

Collision detection

The system checks for actual or near collisions between the part, the in-process workpiece, tooling and fixtures and the machine tool structure.

No need for duplication

There is no need to transfer data to a separate system. It is all inside CAM Express, saving time and reducing errors.

On-machine probing

Available on-machine probing cycles are simulated with solid tools for full visualization.

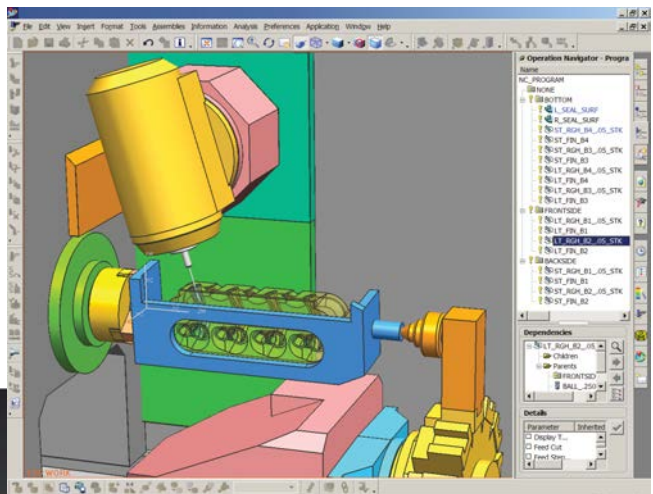

3D models courtesy of Mori Seiki

CAM Express

CAM Express is:

1. An in-depth, highly flexible NC programming system that allows users to maximize the value of their investments in the latest most efficient and most capable machine tools.
2. Available as proven, reliable software from Siemens, the #1 CAM vendor, with more than 25 years of success in the CAM market.
3. Supplied with world-class software support from Siemens.
4. Offered in modular, CAD neutral packages to suit key industry requirements.
5. Available as integrated packages with Siemens CAD applications (NX and Solid Edge) providing full range CAD/CAM with market leading capability and value.
6. Packaged with a comprehensive foundation of core functions from postprocessor creation and editing to shop documentation output.
7. A wide ranging CAM system that enables a shop to have only one CAM software package from one vendor to address all programming and machining simulation requirements.
8. Preconfigured with industry best practices increasing user productivity, with selectable user environments to match key types of machining.
9. Easy-to-deploy and to use with online access to Siemens' postprocessor library and options for complete machine tool support kits.
10. Designed to deliver a low total cost of ownership.

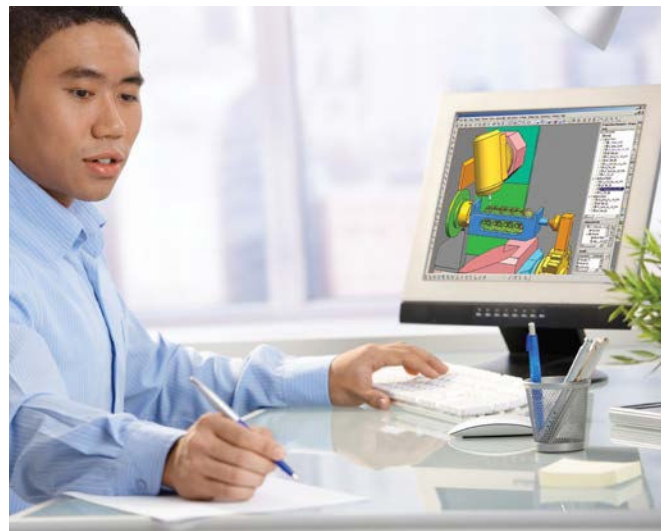

CAM Express packages

The table shows the functional content of each of the CAM Express packages. Each package contains the extensive foundation of core functions.

CAM Express product family

	CAM Express Foundation	CAM Express Total Machining	CAM Express 5-Axis Machining
Foundation	•	•	•
Turning		•	
Wire EDM		•	
2-Axis Milling		•	•
3-Axis Milling		•	•
5-Axis Milling		•	•
NC Simulation		•	•
Feature-based Machining Author		•	
Turbomachinery Milling			

About Siemens PLM Software

Siemens PLM Software, a business unit of the Siemens Digital Factory Division, is a world-leading provider of product lifecycle management (PLM) software, systems and services with nine million licensed seats and 77,000 customers worldwide. Headquartered in Plano, Texas, Siemens PLM Software helps thousands of companies make great products by optimizing their lifecycle processes, from planning and development through manufacturing and support. Our HD-PLM vision is to give everyone involved in making a product the information they need, when they need it, to make the smartest decisions. For more information on Siemens PLM Software products and services, visit www.siemens.com/plm.

Headquarters

Granite Park One
5800 Granite Parkway
Suite 600
Plano, TX 75024
USA
+1 972 987 3000

Europe

Stephenson House
Sir William Siemens Square
Frimley, Camberley
Surrey, GU16 8QD
+44 (0) 1276 413200

Americas

Granite Park One
5800 Granite Parkway
Suite 600
Plano, TX 75024
USA
+1 314 264 8287

Asia-Pacific

Suites 4301-4302, 43/F
AIA Kowloon Tower,
Landmark East
100 How Ming Street
Kwun Tong, Kowloon
Hong Kong
+852 2230 3308

© 2014 Siemens Product Lifecycle Management Software Inc. Siemens and the Siemens logo are registered trademarks of Siemens AG. D-Cubed, Femap, Fibersim, Geolus, GO PLM, I-deas, JT, NX, Parasolid, Solid Edge, Syncrofit, Teamcenter and Tecnomatix are trademarks or registered trademarks of Siemens Product Lifecycle Management Software Inc. or its subsidiaries in the United States and in other countries. All other logos, trademarks, registered trademarks or service marks belong to their respective holders.

8176-X27 11/14 B